

## 200M VGA Audio CAT5 Extender(Local /Adjustable)

**MODEL: LM-102TR**



## **VGA Audio CAT5/UTP/STP Extender**

The 200M VGA Audio Extender transmits VGA video up to 1200 feet (200m) away from a computer using CAT5/5e/6 cable. Each video audio extender consists of a local unit that connects to a computer and also supplies video and audio to a local monitor, and a remote unit that connects to a monitor.

1. Ideal solution for digital signage applications.
2. Supports local and remote VGA monitors.
3. Supports resolutions to 1920x1440.
4. Sharpest and clearest VGA quality over CAT5/UTP-STP cable of any manufacturer.
5. Built-in lightning and ESD surge protection.
6. Available with optional stereo audio or RS232 control.
7. Use in-house CAT5/5e/6 phone wiring to locate a monitor remotely.
8. Optional VESA mounting bracket is available for mounting the remote unit to the back of a flat panel monitor.

## **Specification**

### **1. Local Unit**

#### **1) Host Connection**

- 2) Multiplatform support: Windows  
2000/XP/Vista/Windows7/Server 2000/2003/2008, Solaris,  
Linux, FreeBSD, and MAC OS 9/10.
- 3) Male/Female 15-pin HD connector for computer connection.
- 4) Optional RS232 support - female 9-pin D connector.
- 5) Optional stereo audio support - 3.5mm stereo plug.
- 6) **Local Access**
- 7) Crisp and clear 1920x1440 video resolution.
- 8) Female 15-pin HD connector for local VGA monitor.
- 9) Optional RS232 support - male 9-pin D connector.
- 10) Optional stereo audio support - 3.5mm stereo jack.

## **2. Remote Unit**

- 1) Supports resolutions up to 1920x1440; refer to the resolution chart below for resolutions at different lengths.
- 2) Female 15-pin HD connector.
- 3) Optional 3.5mm stereo audio connection.
- 4) Optional male 9-pin D connector for RS232.

## **3. Video Quality Adjustment**

- 1) Video quality adjustment for different lengths of CAT5/5e/6 cable is done manually for the video-only extender, and automatically for audio/video or video/RS232 extender.

## **4. Environmental**

- 1) Operating temperature: 32°F to 100°F (0°C to 38°C).
- 2) Storage temperature: -20°F to 140°F (-30°C to 60°C).
- 3) Operating and Storage Relative Humidity: 17 - 90%  
non-condensing RH.

## 5. Dimensions

- 1) L\*W\*H (mm): 95\*97\*28mm(Sender)  
  
95\*97\*28mm(Receiver)

- 2) Weight(Kg):0.9KG

## 6. Power

- 1) 220 or 110 VAC at 50 or 60 Hz via AC adapter (Included).
- 2) Power Consumption: 6W (each - local and remote unit).
- 3) Use the PWR-48V-9V0,6A or PWR-12V-9V0,6A DC-DC  
power converter to install the local unit in a Telecom  
environment.

## Application Diagram

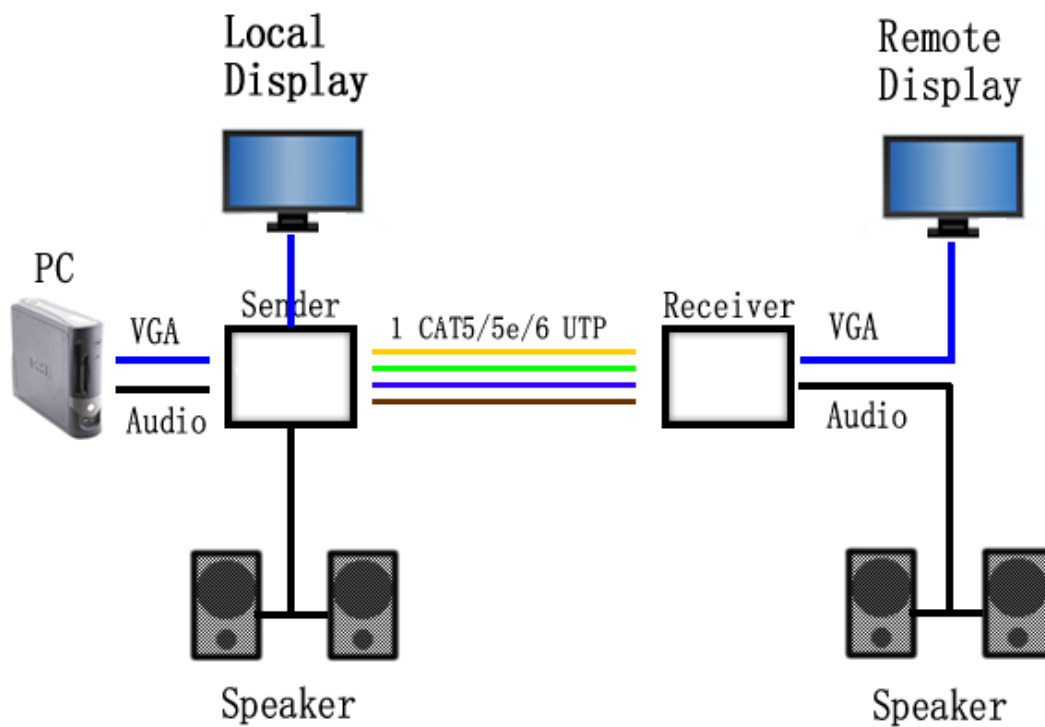

## VGA Audio CAT5/UTP/STP Extension Advantage

### **Move your message across to a digital signage display**

The ultimate out-of-band solution for the last step in a digital signage setup, the VGA Audio Extender is the quickest, most efficient way to move multimedia content from player to display.

### **Transmit VGA audio from any type of player to any type of display device**

A one-to-one, player-to-plasma/LCD system for transmission of high quality audio and video, the VGA Audio Extender transmits rich multimedia from any type of player/computer to any type of electronic display device over standard unshielded or shielded

CAT5 cable.

**Set up the display unit where it is most effective for your business**

The VGA Audio Extender provides the flexibility you need for a customized digital signage installation, allowing you to set up your display device up to 300m/1000ft from its player/computer. The display is mounted strategically in public view, while the hardware needed to run the multimedia content is kept behind closed doors and out of public reach.

**Network free solution for the last step of digital signage**

Delivery of rich, dynamic content via an out-of-band system like the VGA Audio Extender is the most reliable way to ensure real time display without burdening the network.

**Digital signage in your place of business for 1/3 the cost**

It is also one of the more cost effective ways to get a digital signage system up and running in your place of business. Plasmas with built in CPU, which are needed for network content delivery, cost three times as much as regular plasma screens; using a dedicated, out-of-band system like the VGA Audio Extender can lower the cost of a display significantly.